

WaterSoftener⁺ 50

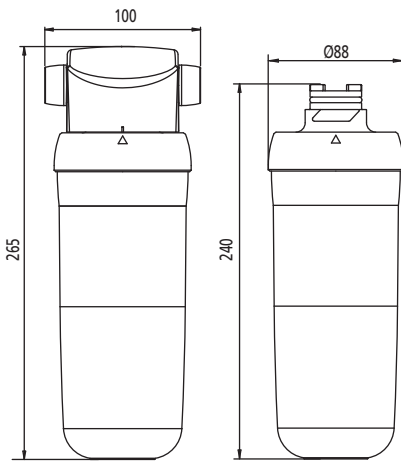

Norit H₂O_K WaterSoftener⁺ 50

Productcode 24.2.501



Dimensions & Weight

Overall length	265 mm
Overall diameter	Ø88 mm
Dry weight system	656 grams

Connection

To mains	3/8" BSP
----------	----------

Storage & Handling

- Keep dry during storage
- Protect against freezing after first use
- Handle with care; do not expose to shocks
- Disposable product; discard as regular waste

Filterhead

Sold separately under productcode 24.2.901



Technology

Ion Exchange Resin
Granular activated carbon (GAC)

Performance (1)

Lifetime 6 months maximum
Flowrate 1.8 l/min
Rated capacity

%kH initial	%kH residual	L total	Beverages
5	2,5	437	2184
6	3	364	1820
7	3,5	312	1560
8	4	273	1365
10	5	218	1092
12	6	182	910
14	7	156	780
16	8	136	682
18	9	121	607
20	10	109	546

Compliance

Chemical reduction (2)	Herbicides & pesticides	> 80 % (Atrazine & 2,4-D)
	Medicine residues	> 90 % (Ethinylestradiol)
	Endocrine disrupting compounds	> 90 % (Bisphenol-A)
Aesthetic & Mechanical effects (3)	Chlorine reduction	> 95 %
	Taste & odor improvement	
Material Safety	Hardness reduction	FDA approved resin
Structural Integrity (4)	Extraction tests	according to NSF/KTW
	Hydrostatic pressure	20.7 bar
	Cyclic pressure	100K cycles of 10.4 bar at 20°C
	Burst pressure	27.6 bar at 20°C

Conditions of use

Max. operating pressure	6 bar
Operating temperature	0 – 40°C
Replace at least every	6 months
	Flush 5 liters before first use

- (1) Product performance is dependent on incoming water conditions
- (2) Tested according to NSF 53
- (3) Tested according to NSF 42 & FDA compliant
- (4) Tested according to NSF general DWTU guidelines

Limited warranty: Filtrix B.V. represents and warrants for the warranty period of one year that its products will be free from substantial defects in materials and workmanship. This warranty is subject to exclusions and limitations. For details on warranty and limitation of liability please refer to our warranty sheet.

Disclaimer: The information and data contained in this document are based on our general experience and are believed to be correct. They are given in good faith and are intended to provide a guideline for the selection and use of our products. Since the conditions under which our products may be used are beyond our control, this information does not imply any guarantee of final product performance and we cannot accept any liability with respect to the use of our products. The quality of our products is guaranteed under our conditions of sale. Existing industrial property rights must be observed.

product data sheet: WaterSoftener⁺ 50